

**TACKBOARD
SERIES 3400**

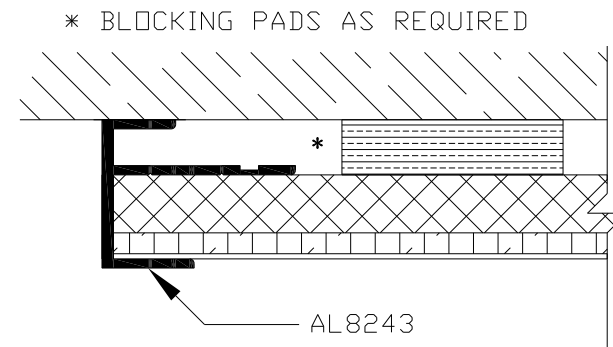

TOP SECTION VIEW

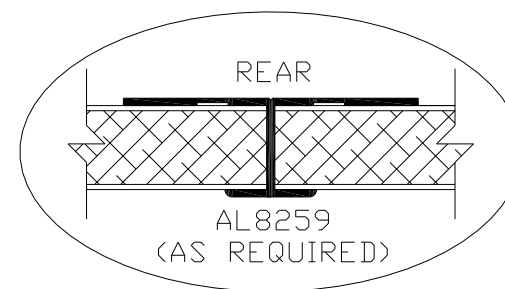

PROJECT: -		JOB # _____
DATE: --/--/--	DRAWN BY: TCW	SCALE: N/A
SUBMITTED FOR: -		
MANUFACTURED BY: MARSH INDUSTRIES, INC. PO BOX 1000 - NEW PHILADELPHIA, OH 44663-5100 PH: (330) 308-8865 FAX: (330) 339-5875		
THIS DRAWING IS PROPRIETARY TO MARSH INDUSTRIES, INC. AND IS FURNISHED SUBJECT TO AN EXPRESSED AGREEMENT NOT TO USE OR DISCLOSE, DIRECTLY OR INDIRECTLY, FOR ANY PURPOSE. THIS LEGEND SHALL BE MARKED UPON ANY REPRODUCTION IN WHOLE OR IN PART HEREOF.		SHEET - OF -